



# MICROCOM

---

SISTEMAS MODULARES, S. L.



# HERMES

## M120

14/06/2012

### **Important**

1. This system has been developed to be installed by qualified personnel, not the final consumer. If you do not understand some of its technical aspects, please contact our experts.
2. Our drive for innovation in software and hardware is ceaseless and, although we make every effort to document our products correctly, there may be times in which inadvertent discrepancies appear between a product and some of its specifications. If you have any queries or comments, please contact us at the following email address: [microcom@microcom.es](mailto:microcom@microcom.es).
3. Although GSM-based communications are extraordinarily reliable, we do advise against using our equipment in critical systems that have no form of redundancy in relation to their communication networks, as the GSM network can simply be temporarily out of service.
4. Life-support systems: This unit is not designed to be used in systems on which human life depends, i.e. in devices whose malfunction could endanger human life.
5. Our liability in connection with the equipment shall be limited to its repair or replacement in accordance with the terms of our warranty.

All rights reserved. No part of this document may be reproduced, stored in a retrieval system or transmitted by any means, including, electronic, mechanical, photocopying, recording, or otherwise, without the prior written permission of Microcom Sistemas Modulares, SL.

Although every precaution is taken to ensure accuracy in the preparation of this document, inadvertent errors or omissions may occur, for which the publisher and author shall assume no liability.

Likewise, no liability shall be assumed for any damage resulting from the use of information contained in this document.

The information contained in this document is subject to change without prior notice and does not represent a commitment on the part of Microcom Sistemas Modulares, SL.

The software described in this document is supplied under a non-disclosure agreement.

This software may be used or copied in accordance with the terms of these agreements.

**© 2003-2012 Microcom Sistemas Modulares, SL. All rights reserved.**

Microcom Sistemas Modulares, S.L.  
C/Gorostiaga, 53 • Irún  
GUIPUZCOA 20305  
Telephone 902 82 06 84 • Fax 943 017 800  
<http://www.microcom.es>

# 1. Introduction

The HERMES M120 is a 4 analogue input module from the Hermes M1xx series. It provides a system with 4 additional analogue inputs.

This advanced acquisition module consists of a 16-bit ADC and an auto-ranging circuit that enables it to offer a voltage range from 0 to 10v and still maintain a resolution of 14 bits for signals as small as 200mV. This makes the M120 perfectly valid for applications that range from signal acquisition in the standard range of 0-10V or 4-20mA to millivolt signals from all types of sensors.

The analogue inputs can operate in 0..4-20mA or 0-10v mode depending on the jumper selection in Fig. 2. The inputs are differential and bipolar, and support up to 20v in common mode over 0v reference (GND of the master module). Because of these features, in most applications, the installation of galvanic isolators is not required.

# 2. Product presentation

Fig. 1 shows a front-on view of the module and the position of the status LEDs and address selection switch. Figure 2 shows the layout of the configuration jumpers.



Fig. 1

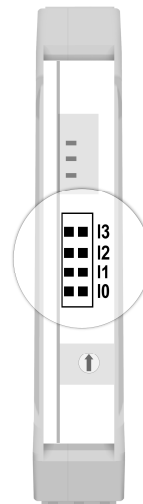

Fig. 2

### LED description:

LED	MEANING
<b>PWR</b>	Indicates that the equipment has power
<b>TX</b>	Transmission by the internal bus to the master module
<b>RX</b>	Reception by the internal bus from the master module

### Address selection:

With the address selection switch, it is possible to select one of 16 addresses, from 0 to F, which must coincide with that selected in the module's configuration software.

### Configuration of the inputs in 0-10v or 0..4-20mA mode:

Fig. 2 shows the layout of the jumpers for selecting the operating mode of the inputs. These are accessible by removing the front cover. With the jumper in place, the corresponding input is configured in 0..4-20mA mode. When removed, the input is in voltage mode. Jumper I0 corresponds to input 0 and so on up I3.

**At the factory, all inputs are configured in 0..4-20mA mode.**

### 3. Connection of the analogue inputs

Connection of a 4-20mA passive sensor:

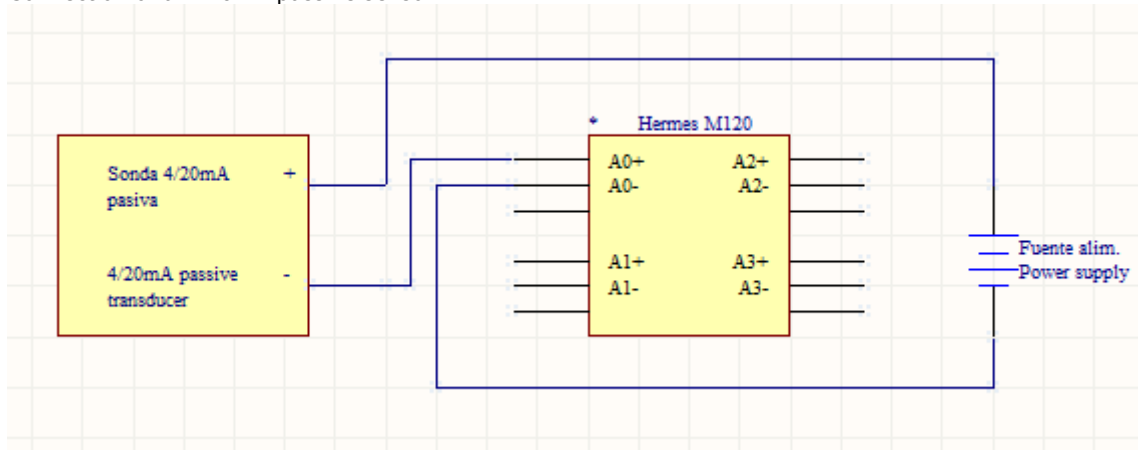

Connection of a 4-20mA active sensor:

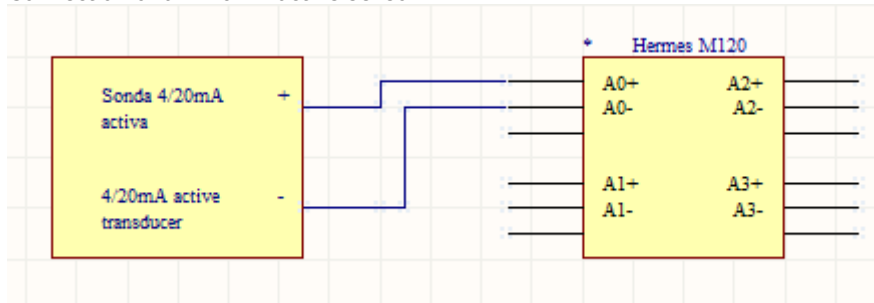

### 4. Technical specifications

<b>Consumption</b>	<b>200mW</b>
<b>Processor</b>	<b>RISC 8 bits @ 11.0592MHz</b>
<b>Size</b>	<b>DIN box. One unit size. 105 x 90 x 58</b>
<b>Weight</b>	<b>250g</b>
<b>Operating temperature</b>	<b>-10°C to +75°C</b>

#### ANALOGUE INPUTS:

<b>Number</b>	<b>4</b>
<b>Type</b>	<b>Differential and bipolar</b>
<b>Impedance</b>	<b>0-10v: 1MΩ 4-20mA: 125Ω</b>
<b>Range</b>	<b>0-10v or 0..4/20mA</b>
<b>Accuracy</b>	<b>0.1%</b>
<b>Resolution</b>	<b>16bits</b>
<b>Maximum voltage in common mode</b>	<b>20v</b>

## 5. Warranty

1. MICROCOM guarantees that this product is free from defects in materials and workmanship **for five years**, during which time its sole obligation under this warranty is to repair or replace, without charge, any of the equipment's parts whose materials or workmanship are deemed to be faulty after an examination has been performed by MICROCOM, and only under the conditions listed below.

a) MICROCOM has been informed of the fault in writing within five years of the date of purchase of the equipment.

b) The equipment has not been maintained, repaired or altered by any person who has not been previously approved or authorised by MICROCOM.

c) The equipment has been used properly and normally, and has not been altered or misused, broken by accident or damaged by an act of God or other similar catastrophic incident.

d) The purchaser, either the DISTRIBUTOR or the DISTRIBUTOR's client, packs and sends, or delivers, the equipment to MICROCOM's factory in Irun, Spain, within a maximum of 30 days after MICROCOM receives written notification of the fault.

**The cost of sending the equipment to MICROCOM shall be borne by MICROCOM if sent from within Spanish territory.**

e) MICROCOM's liability is limited to repairing or replacing any of the equipment's parts without charge, provided that the examination performed by MICROCOM reveals that the part is faulty due to a defect in materials or workmanship.

1.1. The DISTRIBUTOR or the DISTRIBUTOR's clients may send the equipment directly to MICROCOM if the DISTRIBUTOR is unable to repair the equipment, even if it has been approved to do so, and the DISTRIBUTOR has agreed with the client to have the repairs performed as covered by this limited warranty.

1.2. In the event that a product needs to be returned to MICROCOM for repair under the warranty, the DISTRIBUTOR must contact MICROCOM prior to sending in order to receive a Return Materials Authorisation number (RMA).